

Data sheet

Commercial Art.No.: 56.395.1055.0

feed-through terminal RFK 1 / 95 FM S35/V0

Feed-through terminal with Screw connection for mounting on TS 35/7,5 mm, nominal cross section: 95 mm², width: 32 mm, color: grey

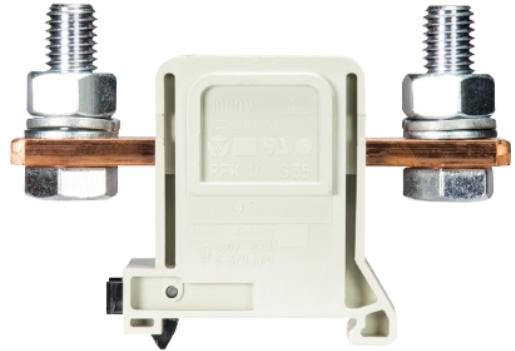

Commercial Art.No.	56.395.1055.0
EAN	4015573568747
Order Unit	10

certificates / approvals



Technical data

general

nominal cross section	95 mm ²
color	grey
number of levels	1
number of clamp positions per level	2
width/grid dimension	32 mm
insulating housing	PA666
flammability class of insulation material acc. with UL94	V0
explosion-tested version "Ex e"	no
mounting method	DIN rail (top hat rail) 35/7.5 mm
terminal blocks for electrical installations	no
Anzahl der Klemmstellen je Etage	2
Montageart	DIN rail (top hat rail) 35/7.5 mm
Brennbarkeitsklasse des Isolierstoffs	V0
Reihenklammern für Installationsverteiler	no

technical data

rated current	250 A
rated voltage	1000 V
pollution degree	3
closing plate required	no
type of insulation material	thermoplastic
length	92 mm

connection data

connection type 1	screw connection
connection type 2	screw connection
minimum cross section fine stranded	16 mm ²
maximum cross section fine stranded	95 mm ²
minimum cross section stranded	16 mm ²
maximum cross section stranded	95 mm ²
torque conductor mounting	10 Nm

technical data UL/CSA

cross section UL	6-3/0 AWG
voltage UL	600 V
current factory wiring	200 A
current field wiring	200 A
cross section CSA	6-3/0 AWG
voltage CSA	600 V
current CSA	200 A

classification

ECLASS 11	
ECLASS 8.1	27141120
ETIM 9.0	EC000897
ETIM 8.0	EC000897
ETIM 7.0	EC000897
ETIM 6.0	EC000897
ETIM 5.0	EC000897
ETIM 4.0	EC000897
ETIM 3.0	EC000897

product compliance

ROHS conformity status	compliant
REACH-SVHC conformity status	compliant

Accessories

Commercial Art.No.:	Article-type description:	Description:

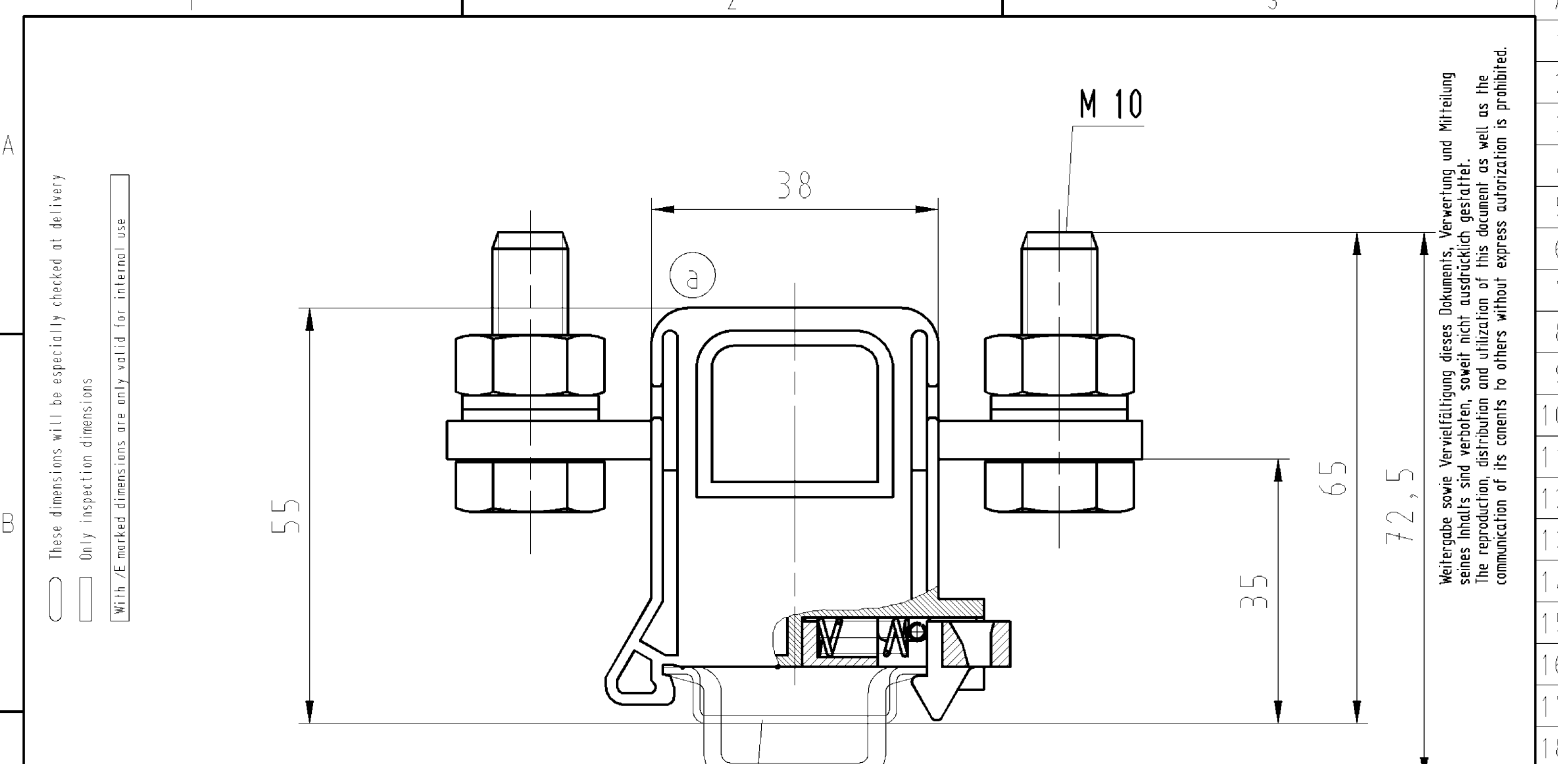

Hutschiene EN 60715-35x15
mounting rail EN 60715-35x15

Hutschiene EN 60715-35x7,5
mounting rail EN 60715-35x7,5

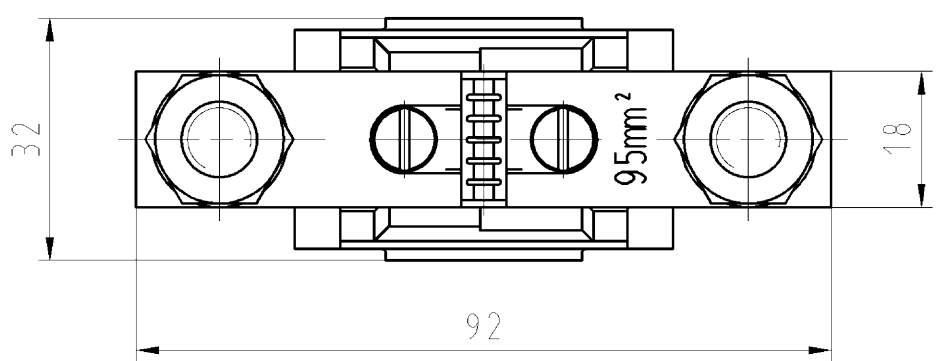

Weitere Daten siehe Katalog
further data see catalog

Weitergabe sowie Vervielfältigung dieses Dokuments, Verwertung und Mitteilung seines Inhalts sind verboten, soweit nicht ausdrücklich gestattet. Die Reproduktion, Distribution und Utilization of this document as well as the communication of its contents to others without express authorization is prohibited.

These dimensions will be especially checked at delivery
 Only inspection dimensions
 With /E marked dimensions are only valid for internal use

Diese Maße werden bei Abnahme besonders geprüft
 Ausschließlich Prüfmaße
 Mit /E gekennzeichnete Maße sind nur für interne Zwecke gültig

Tolerierung Size ISO 14405(☐)/Tolerance system Size ISO 14405(☐).
 (This ISO-standard describes the envelope principle. According to the envelope principle the deviations of form and parallelism are limited by the size tolerances).

ja/yes Stoffverbots- und Deklarationsliste nach UU-TQM-05/03 ist einzuhalten.
 Conformity with Wieland document UU-TQM-05/03 (list of prohibited / declarable hazardous substances) to be declared!

Freitoleranz nach DIN ISO 2768 - m CAD - Zeichnung, keine manuellen Änderungen
 General tolerance CAD - drawing, no manual modifications allowed

I.Verwendung: - Blatt: 1 von 1
 First Use: Sheet: 1 of 1

	/		Werkstoff/Material	2003	Tag/Date	Name	Zeichnung Nr./Drawing No.	Index
	/			gezeichnet drawn	16.04.	Schneiderb.		
	/			geprüft checked	-	-		
	/			Normgepr. Stand., check	-	-		
	/	Maßstab/Scale					56.395.1055.0 01K a	a
	/	1:1	Maße in mm/Dimensions are in mm					
	/	Vol.	mm³	Öl./Surf.	mm²	Ersatz für/Replacement for: -		

	/		wieland Elektrische Verbindungen	Type	Benennung/Tittle	
a	23.08.2012/			RFK 1/95	REIHENFLACHKLEMME	
Index	Datum / Blatt Date / Sheet			FM S35/V0	terminal	
Änderung/Revision						

563951055001K_2 CADW2036.treschan 2012-08-23 10:51:25 1.000